



DUST EXTRACTION & VACUUMS



Regularly **breathing construction dust** can cause **life-changing lung diseases** like Lung Cancer, asthma, Chronic Obstructive Pulmonary Disease (COPD)

Types of Construction Dust

- Silica dust from concrete, mortar and sandstone
- Wood dust from softwood, hardwood and wood-based products like MDF and plywood
- Lower toxicity dusts from plasterboard, limestone, marble and dolomite

Common Construction Tasks Creating Dust

- Cutting paving blocks, kerbs and flags
- Chasing concrete and raking mortar
- Cutting roofing tiles
- Scrabbling or grinding
- Soft strip demolition
- Dry sweeping
- Cutting and sanding wood
- Sanding taped and covered plasterboard joints



Saves time and money – packing away is quicker, allows getting home or moving on to the next job quicker



Better health & wellbeing – reduced risk of serious lung diseases



Reduced working days lost due to workplace illness



Used appropriately to meet legal requirements / no HSE fines for inefficient, wrong or no dust extraction



THREE CLASSES

- **L Class $\leq 1.0\%$ Dusts with maximum allowable concentrations (MAC) $> 1 \text{ mg/m}^3$**

Soft woods and solid surface material (e.g. Corian)

Filters 99% of all air

$<1\%$ of extracted dust passes out of the filter



- **M Class $< 0.1\%$ Dusts with maximum allowable concentrations (MAC) $\geq 0.1 \text{ mg/m}^3$**

For hard woods, board materials, concrete and brick dust

Filters 99.9%

$<0.1\%$ of extracted dust is passed out of the filter



- **H Class $< 0.005\%$ Dusts with maximum allowable concentrations (MAC) $< 0.1 \text{ mg/m}^3$**

Highly carcinogenic dusts, asbestos, formaldehyde, mould, germs and bacteria

Filters 99.995%

Releases $<0.005\%$ of dust back into the air



HEPA

Many people often mistake this for believing it to be a brand or manufacturer, and this is not true. It is important to note that HEPA is a type of air filter.

HEPA was commercialized in the 1950s, and the original term became a registered trademark and later a generic term for highly efficient filters.

HEPA stands for “High Efficiency Particulate Arresting”

HEPA

To qualify as a “True HEPA” an air filter must remove (from the air that passes through) 99.97% of particles that have a size of 0.3 microns in diameter.

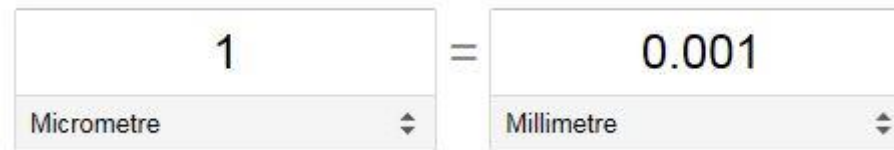

A diagram illustrating the conversion between micrometres and millimetres. It consists of two input fields separated by an equals sign. The left field contains the number '1' and a dropdown menu with 'Micrometre' selected. The right field contains the number '0.001' and a dropdown menu with 'Millimetre' selected.

$$1 \text{ Micrometre} = 0.001 \text{ Millimetre}$$

Products that claim to be "HEPA-type", "HEPA-like", "HEPA-style" or "99% HEPA" do not satisfy these requirements and may not have been tested in independent laboratories



HEPA	
Filter Class	Efficiency (%)
E 10	≥ 85
E 11	≥ 95
E 12	≥ 99,5
H 13	≥ 99,95
H 14	≥ 99,995
U 15	≥ 99,999 5
U 16	≥ 99,999 95
U 17	≥ 99,999 995

- HEPA = **H**igh **E**fficiency **P**articulate **A**bsorber
- A generic term to describe a high efficiency filter
- Consists of a mat of randomly arranged fibreglass layers
- European Standard = EN 1822-1:2009
- The filter must remove 99.95% of particles that have a size greater than or equal to 0.3 microns (µm)

In 2007, DEWALT created the most comprehensive system in the world for tools dedicated to safety

Products that meet strict criteria in one or more of core safety-focused areas:



CONTROL



VIBRATION



DUST



Guarantees the potential of inhaling dust is dramatically reduced to give a cleaner and safer working environment



DUST EXTRACTORS & VACUUMS PRODUCT HIERARCHY



	SDS Plus Dust Extractor	Drilling Dust Extraction System & Hole Cleaning	Chiselling Dust Extraction System	Demolition Dust Extraction System	18V Dust Box Evacuator	18V Cordless SDS-Plus Dust Extractor + Dust Box Evacuator	SDS-Plus Dust Extractor + Dust Box Evacuator	18V XR Hand Held Wet & Dry Vacuum	18V XR L-Class Vacuum & Extractor	30L Compact L-Class Dust Extractor	38L Construction M-Class Dust Extractor	11L 54V XR FLEXVOLT M-Class Dust Extractor
Product Code	DWH201D	DWH050	DWH051	DWH052	DWH079D	D25303DH	D25304DH	DCV517	DCV584L	DWV901L	DWV902M	DCV586M
Tool Holder / Hose Connection	SDS Plus	SDS Plus	SDS-Max/19mm HEX	Demolition	AirLock	SDS Plus	SDS Plus		AirLock	AirLock	AirLock	AirLock
Class									L-Class	L-Class	M-Class	M-Class
Voltage					18V				18V	240V or 110V	240V	54V
Power Input							180 Watts	300 Watts	300 Watts	1400 Watts	1400 Watts	
Max. Power									3000 Watts (240V) 1840 Watts (110V)	3000 Watts (240V) 1840 Watts (110V)	3000 Watts (240V) 1840 Watts (110V)	
Variable Flow											Yes	
Max. Airflow							15.9 l/sec	15.9 l/sec	68.0 l/sec (240V) 64.0 l/sec (110V)	68.0 l/sec (240V) 64.0 l/sec (110V)	68.0 l/sec (240V) 64.0 l/sec (110V)	24.7 l/sec
Tank Capacity							1.9L	7.5L	30L	38L	11L	
Wet/Dry Capacity							1.9L	7.5L	17.5L	18.4L	7.5L	
Max. Drill Bit Diameter	25mm	52mm		32mm		16 mm	26 mm					
Max. Drill Bit Length	250mm					160 mm	250 mm					
Max. Drilling Depth	129mm	Unlimited	Unlimited	Unlimited		105 mm	180 mm					
Hose Length	1000mm							1m	2 m	4.1 m	4.1 m	2.4m
Hose Diameter	30mm	30mm	30mm	30mm				32 mm	32 mm	32 mm	32 mm	32mm
IP Rating								IPX4	IPX4	IPX4	IPX4	
Sound Pressure								76 dB(A)	76 dB(A)	80 dB(A)	75 dB(A)	69 dB(A)
Sound Pressure Uncertainty								3 dB(A)	3 dB(A)	3 dB(A)	3 dB(A)	3.5 dB(A)
Sound Power								87 dB(A)	87 dB(A)	93 dB(A) (240V) 94 dB(A) (110V)	88 dB(A)	81.5 dB(A)
Sound Power Uncertainty								3 dB(A)	3 dB(A)	3 dB(A)	3 dB(A)	3.5 dB(A)
Dimensions (Height, Length, Width)	256x125x136mm				152x210x136mm	242x340x116mm	296x440x136mm	200x460x160mm	430x330x305mm	Height 500mm		
Weight	1.068Kg				0.492Kg	1.4Kg	1.4Kg	1.8Kg	4.8Kg	9.5Kg	15Kg	6.5Kg
Product Code	DWH201D-XJ	DWH050-XJ	DWH051-XJ	DWH052-XJ	DWH079D-XJ	D25303DH-XJ	D25304DH-XJ	DCV517N-XJ	DCV584L-GB	DWV901L-GB (240V) DWV901L-LX (110V)	DWV902M-GB (240V) DWV902M-LX (110V)	DCV586MT2-GB (2 x 6Ah) DCV586MN-XJ (Bare)

Users

Any trade requiring dust management solutions

- Construction site workers
- Plumbers
- Electricians
- General builders
- General contractors
- Flooring contractors
- Dryliners
- Onsite contractors

Many more...



Applications



Chipping / Demolition

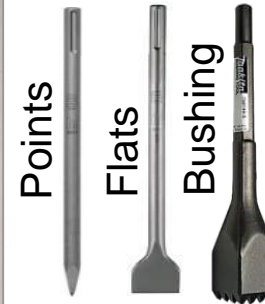

Drilling



Legislation Compliance

- Reduces airborne dust
- Encouraged on site
- DEWALT leading dust reduction

Health & Safety

- Reduces site 'dust prevention' costs
- Combats Silicosis & other dust related diseases

Compatibility

- All DEWALT 5, 6, 7, 9, 10, 12, 16 & 30 Kg's
- Innovative extractor connectivity

Drilling & Chipping Solution

- Total large hammer solution
- All common applications covered
- Accepts most drill bits and chisels

DRILLING DUST EXTRACTION SYSTEM & HOLE CLEANING



DWH050

CHISELLING DUST EXTRACTION SYSTEM



DWH051

5-12Kg

DEMOLITION HAMMER DUST EXTRACTION



DWH052

16-30Kg

- ✓ Complete Solution
- ✓ Excellent Connectivity
- ✓ Durability

DWH201D



Replaces D25301D

Sleeve Fits DEWALT SDS-Plus Hammers (18V, 54V & Coded) Plus Premium Drills

For system compatibility
Versatility

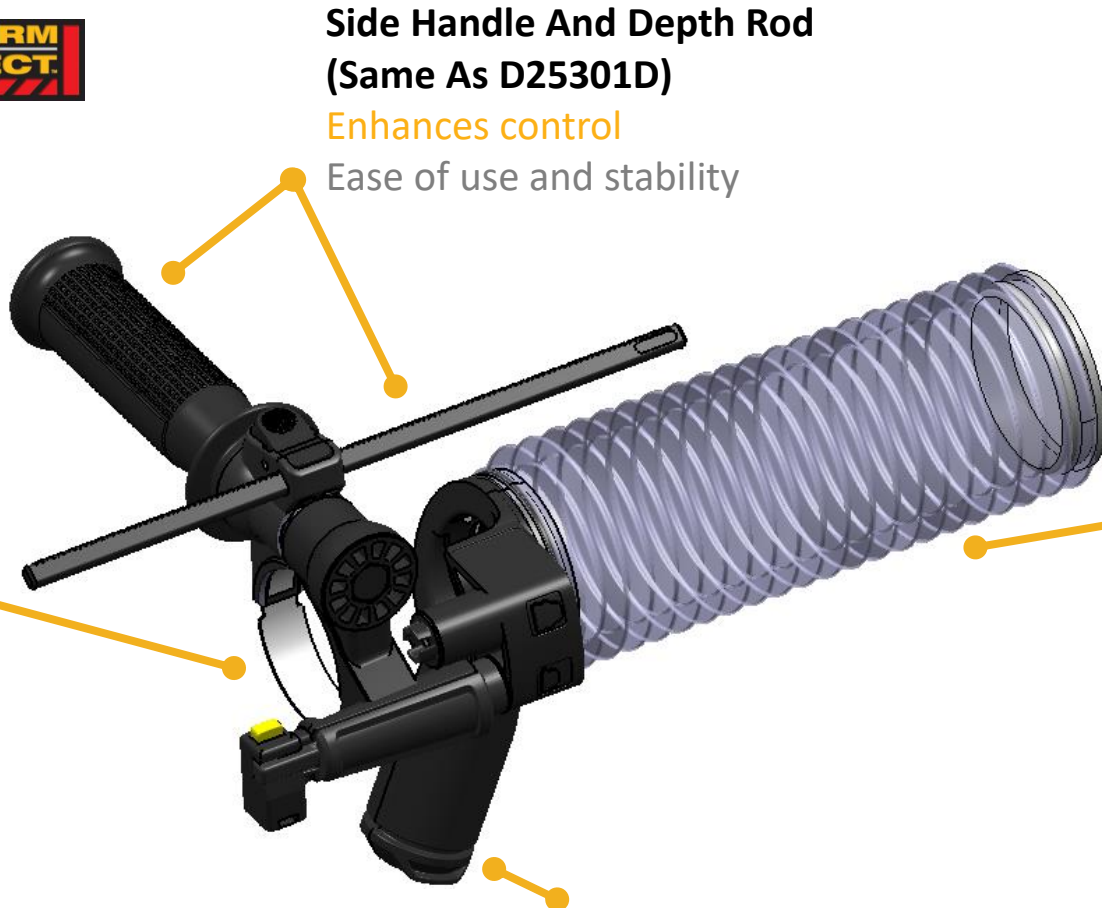

Side Handle And Depth Rod
(Same As D25301D)

Enhances control
Ease of use and stability

250mm Or 160mm Sleeves
For use with long bits or short bits for various applications
Versatility

	Result
Max. Drill Bit Diameter	25mm
Max. Drill Bit Length	250mm
Max. Drilling Depth	129mm
Max. Chisel Diameter	25mm
Hose Length	1000mm
Hose Diameter	30mm



Use With Airlock Hose Or Without Using Plug
Connects to DEWALT Extractors for system compatibility or use as a standalone collector
Versatility

160MM, 250MM SLEEVES & 150MM HOSE INCLUDED

DWH201D-XJ

- Collects dust and debris during drilling. Can be used with a dust extractor for complete dust collection, or alone as a collector
- Quick-fit system for easy tool free assembly and release
- For use with DEWALT corded and cordless SDS-Plus hammers
- Ideal for dust free drilling up to 25mm diameter
- Tough and versatile to meet the needs of the most demanding applications with a compact design to maintain visibility and extremely light weight to minimise user fatigue
- 1000mm heavy duty rubber hose for maximum reach
- Side handle adaptor for increased compatibility and depth rod for ease of use
- Includes side handle with dust extraction adaption, rubber hose, 250mm long and 160mm short accordion collectors. Packaged in a cardboard branded box

DEWALT 1 Year
Guarantee



Barcode:
5035048705407

SDS PLUS DUST BOX EVACUATOR



DWH079D



Listed separately in the price list



and



Included FOC in D25303DH
18V Cordless Dust Extraction
System



Included FOC in D25304DH
SDS Plus Dust Extractor
Corded Cordless



SDS PLUS DUST BOX EVACUATOR

DWH079D



Reverse Airflow*

Empties dust box in <30s
For reduced downtime

Ergonomic Design*

Sits flatly on DEWALT extractors
Compatibility

Compatible With SDS-Plus Dust Boxes
In D25303DH And D25304DH Integrated Extractors

System compatibility
Versatility



AIRLOCK Connection*
Dust management
Safety

Available boxed on it's own or included **free of charge**, boxed separately, with D25303DH & D25304DH SDS Plus Extraction Units

Simple to attach and Evacuate in 3 steps

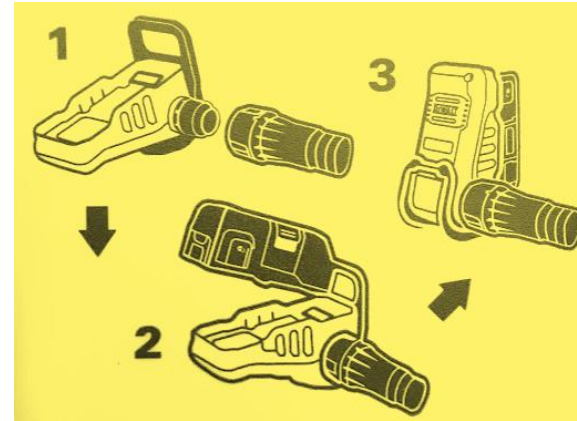

Dust Excavator DWH079D
Dust Box from D25303DH or D25304DH



Or other Airlock dust collection system



Reduces dust, increased safety

* Key features

SDS-PLUS DUST EXTRACTOR



D25304DH

18V CORDLESS SDS-PLUS DUST EXTRACTOR



D25303DH



D25304DH



HEPA Filter*

Captures 99.5% of particles 0.3 microns or larger

Excellent worker protection and washable to enhance lifetime

Manual Filter Cleaning Mechanism

Excellent worker protection

Safer environment

Retrofitable For D25303DH

One solution

Compatibility



Fits Up To 26mm Bits*

Compatibility for various applications whilst maintaining excellent suction
Versatility



180mm Max Drilling Depth*

Deep drilling

For various applications

No Motor, Powered By Hammer*

Works by a mechanical drive that activates the extractor

Reduced weight



Fits DCH333, DCH334 (54V XR FLEXVOLT) And D25333K, D25334K 3Kg Coded Hammers*

One solution

Versatility

Tool Free For Assembly

Quick and easy attachment

Saves time

**DWH079D
DUST EVACUATOR
INCLUDED IN A
SEPARATE BOX**



	Result
Max. Drill Bit Diameter	26mm
Max. Drill Bit Length	250mm
Max. Drilling Depth	180mm

* Key features

D25303DH

HEPA Filter*

Captures 99.5% of particles 0.3 microns or larger
Excellent worker protection and washable to enhance lifetime

Manual Filter Cleaning Mechanism

Excellent worker protection
Safer environment

Retrofitable For D25303DH

One solution
Compatibility



	Result
Max. Drill Bit Diameter	16mm
Max. Drill Bit Length	250mm
Max. Drilling Depth	160mm

Fits Up To 16mm Bits*

For various applications whilst maintaining excellent suction
High performance drilling



160mm Max Drilling Depth

For various applications
Versatility

POWERED BY MOTOR*

Offers excellent suction
High performance drilling

Fits DCH273, DCH274, DCH253 (Type 2), DCH254 (Type 2) (18V XR 2KG SDS PLUS Hammers)*

One solution
Versatility

Tool Free For Assembly

Quick and easy attachment
Saves time

DWH079D DUST EVACUATOR INCLUDED IN A SEPARATE BOX



* Key features

DCV517

Toggle On/Off Switch

Convenient
Ease of use

Detachable Flexible Hose

To get into difficult to reach areas
Ease of use

On-Board Hose Storage*

For easy transport and storage
Convenience and safe



Single Latch*

For easy tank removal
Quick and easy emptying
of the tank



Washable Filter*

Captures 99.7% of particles
0.3 microns or larger
Excellent worker protection and
washable to enhance lifetime

Compatible With

14V/18V & 54V FLEXVOLT XR Batteries*

System compatibility and mains supply
Versatility

Wet / Dry Vacuum*

Without changing the filter
Versatility



	Result
Power Input	180 Watts
Max. Airflow	15.9 l/sec
Tank Capacity	1.9L
Wet/Dry Capacity	1.9L
Hose Length	1m
Hose Diameter	32 mm
IP Rating	IPX4
Sound Pressure	76 dB(A)
Sound Pressure Uncertainty	3 dB(A)
Sound Power	87 dB(A)
Sound Power Uncertainty	3 dB(A)

* Key features

DCV584L-GB

- Runs off 18V XR battery platform allowing quick and easy change between different tools with a single
- The rubber hose is extendable to 1 metre for added flexibility for a wide range of applications
- 1.9 Litre tank capacity allows for the cleaning up of larger amounts of material
- High efficiency filter traps 99.7% of dust as small as drywall and cement dust
- Single latch tank removal allows for quick and easy emptying of the tank
- Includes wide nozzle, 1 metre hose and crevice tool. Boxed in branded cardboard packaging



Barcode:

5035048648865





18V XR L-CLASS VACUUM/DUST EXTRACTOR

DCV584L



Replaces DCV582

**Compatible With
14V/18V & 54V FLEXVOLT XR Batteries***
System compatibility and mains supply
Versatility

AIRLOCK™ Compatible*

Allows direct, secure attachment
DEWALT AirLock™ tools
System compatibility



**On-Board Accessory & Mains
Cord Storage***

For easy transport and storage
Convenience and safe

L-Class Vacuum*

High efficiency filtration
Safer environment

Blower Function

For tool and job area
dust and debris cleaning option
Multi-use

HEPA Filter*

Captures 99.5% of particles
0.3 microns or larger
Excellent worker protection and
washable to enhance lifetime

	Result
Tool Holder / Hose Connection	AirLock
Class	L-Class
Voltage	18V
Power Input	300 Watts
Max. Airflow	15.9 l/sec
Tank Capacity	7.5L
Wet/Dry Capacity	7.5L
Hose Length	2 m
Hose Diameter	32 mm
IP Rating	IPX4
Sound Pressure	76 dB(A)
Sound Pressure Uncertainty	3 dB(A)
Sound Power	87 dB(A)
Sound Power Uncertainty	3 dB(A)



On-Board Hose Storage*

For easy transport and storage
Convenience and safe

Wet / Dry Vacuum*

Without changing the filter
Versatility



* Key features

DCV584L-GB

- Operates on 14.4V / 18V and 54V FLEXVOLT XR battery packs plus runs on a 240V mains supply
- L-Class vacuum offers high efficiency filtration for safer environment
- High efficiency washable HEPA filter traps 99.97% of dust as fine as 0.3 Microns
- On-board hose, cord and accessory storage provides convenient transport and storage
- Versatile on the jobsite, vacuums wet or dry without the need to change the filter
- Use as an extractor by attaching to tools with hose and AIRLOCK accessories
- Includes wide nozzle, 2 metre hose, crevice tool. Boxed in branded cardboard packaging



Barcode:

5035048648865



DWV901L



240V OR 110V

Constant Suction Control

Excellent for fine concrete and wood dust
Versatility

Automatic Start & Stop Control (Continues to run for 15 seconds)

Activates when power tool is operated
Saves power, reduces jobsite noise

Audible Alarm*

Alerts user of a drop in performance
Optimizes performance

	Result
Product Code	DWV901L
Tool Holder / Hose Connection	AirLock
Class	L-Class
Voltage	240V or 110V
Power Input	1400 Watts
Max. Power	3000 Watts (240V) 1840 Watts (110V)
Max. Airflow	68.0 l/sec (240V) 64.0 l/sec (110V)
Tank Capacity	30L
Wet/Dry Capacity	17.5L
Hose Length	4.1 m
Hose Diameter	32 mm
IP Rating	IPX4
Sound Pressure	80 dB(A)
Sound Pressure Uncertainty	3 dB(A)
Sound Power	93 dB(A) (240V) 94 dB(A) (110V)
Sound Power Uncertainty	3 dB(A)



L-Class Vacuum*

High efficiency filtration
Safer environment

Innovative Dual Filter Cleaning (Cleaned Every 30 Seconds)*

Reduces filter clogging, delivers constant air flow
Maintains performance

AIRLOCK™ Compatible*

Allows direct, secure attachment to DEWALT
AirLock™ tools
System compatibility



Power Take Off Socket

Allows power tool connection
Automatic switching of the
vacuum system

Wet / Dry Vacuum*

Without changing the filter
Versatility



* Key features

DWV901L-GB

DWV901L-LX

- Automatic start and stop control when the power tool is operated. The machine continues to run for an extra 15 seconds to allow all dust to be cleared from system
- Wet and dry pick up
- Durable tank construction suitable for tough jobsite applications
- Built-in power take off socket allows power tool connection for automatic switching of the vacuum system
- Constant suction power even with the finest concrete and wood dust
- L Classified to meet EU legislation
- Innovative dual filter cleaning system maintains performance during tough construction applications dust
- A filter is automatically cleaned every 30 seconds reducing filter clogging and delivering constant air flow
- Includes dust bag , 4m x 32mm extraction hose, 35mm AirLock adapter. Boxed in branded cardboard packaging



DWV901L-GB

Barcode:

5035048467411

DWV901L-LX

Barcode:

5035048467428



DWV902M

240V OR 110V



Variable Suction Control

Allows for the reduction of suction power
Versatility

**Automatic Start & Stop Control
(Continues to run for 15 seconds)**

Activates when power tool is operated
Saves power, reduces jobsite noise

Audible Alarm*

Alerts user of a drop in performance
Optimizes performance

Power Input	1400 Watts
Max. Power	3600/3000 Watts (240V)
Variable Flow	1840 Watts (110V)
Max. Airflow	Yes
Tank Capacity	68 l/sec (240V)
Wet/Dry Capacity	64 l/sec (110V)
Hose Length	38L
Hose Diameter	18.4L
IP Rating	4.1 m
Sound Pressure	32 mm
Sound Pressure Uncertainty	IPX4
Sound Power	75 dB(A)
Sound Power Uncertainty	3 dB(A)
	88 dB(A)
	3 dB(A)

Power Take Off Socket

Allows power tool connection
Automatic switching of the vacuum system

Wet / Dry Vacuum*

Without changing the filter
Versatility



Telescoping handle

Easy transportation over jobsite
Convenience

M-Class Vacuum*

High efficiency filtration
Site compliant
Safer environment

**Innovative Dual Filter Cleaning
(Cleaned Every 30 Seconds)***

Reduces filter clogging, delivers constant air flow
Maintains performance

AIRLOCK™ Compatible*

Allows direct, secure attachment to DEWALT
AirLock™ tools
System compatibility



Large Rear Wheels*

Easy transportation over jobsite
Convenience



* Key features

DWV9500-XJ

TSTAK VAC RACK ADAPTER



- Adapter allows TSTAK Kit Boxes to connect with DWV901L and DWV902M Dust Extractors

Barcode:

5035048467480

T-STAK®

System Compatible

Compatibility

Across Dewalt Storage

DWV9400-XJ

PLASTIC TANK LINERS (5 PACK)



- 5 Filter Bags for D27901/ D27902

Barcode:

5035048434444

DWV9401-XJ

PAPER DUST BAGS
FOR DWV902 (5 PACK)



- 5 Filter Bags for D27901/ D27902

Barcode:

5035048434451

DWV9402-XJ

FLEECE DUST BAGS FOR DWV902
(5 PACK)



- 5 Filter Bags for D27901/ D27902

Barcode:

5035048434468

DWV9340-XJ

REPLACEMENT FILTER FOR
DWV902M TYPE 2 & DWV900L
(2 PACK)



- Replacement Filter for DWV902M Type 2 & DWV900L
- 2 pack
- For wet and dry use

Barcode:

5035048696712

DEWALT 1 Year
Guarantee



54V XR FLEXVOLT M-CLASS DUST EXTRACTOR

DCV586M



TSTAK® Compatible*

Configure to exact storage requirements
Ease of use, enhanced mobility, saves time

4mm Reinforced Polypropylene Plastic

High impact, drop resistant
Increased durability, jobsite tough

Heavy Duty Metal Clips

Access to Tank & Filters
Quick and Easy

Wet & Dry*

Maximum clean up flexibility
Versatility

Automatic Dual Filter Cleaning*
(Filter cleaned every 30 seconds)
Reduces filter clogging, delivers constant airflow
Maintains performance

Durable Recessed Carry Handle
Increased portability
Saves time

2000W Brushless Motor*
Powerful and market leading
overload protection
Increased performance

**Wireless Vac Activation
Remote/Key Fob Activation***
No need to switch on at source
Ease of use, saves time



Audible Alarm*
Alerts user of a drop in performance
Optimizes performance

M-Class Compliant*
< 0.1% dust escape through filter, suitable for use on construction sites
Increased performance

**Recessed Battery Crevice
Fits XR FLEXVOLT Batteries***
Maximum battery protection. Maximum power and runtime
Extended durability, efficiency and power

Dust Tight, Water Resistant*
Maximum protection against severe conditions
Increased durability

On Vac 2.4m Hose Storage*
Protective hose storage
Ease of use and safe



	Result
Capacity	11L
Filter Clean	Automatic
Hose Length	2.4m

* Key features





54V XR FLEXVOLT M-CLASS DUST EXTRACTOR REMOTE / KEY FOB ACTIVATION

- Insert key fob into holder
- Wrap strap around
- Strap to vacuum hose, finger or close by the work area
- Press to activate/deactivate

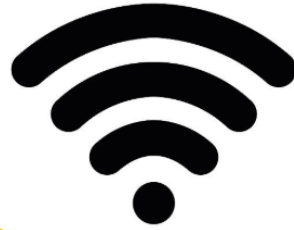
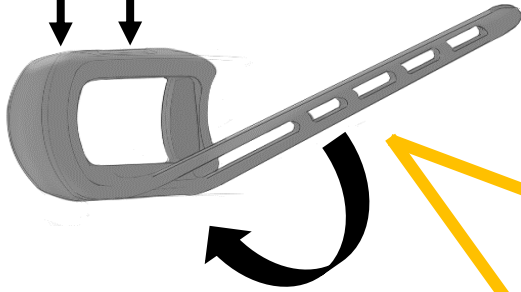

*Video of key fob
in use*

Wireless Vac
Activation

No need to switch on
at source





54V XR FLEXVOLT M-CLASS DUST EXTRACTOR STORAGE & ACCESSORIES



T-STAK®
System Compatible
Compatibility
Across Dewalt Storage

DWV9316-XJ
Antistatic
Dust Extractor Hose 4M



- 4M x 35MM Antistatic Extractor Hose
- Fits DCV586M, DWV901L & DWV902M

Barcode:
5035048434437

DCV9401-XJ
Paper Bags For DCV586M
Dust Extractor (5 Pack)



- Replacement paper bags for DCV589M Dust Extractor (5 Pack)

Barcode:
5035048696736

DCV9402-XJ
Fleece Bags For DCV586M
Dust Extractor (5 Pack)



- Replacement fleece bags for DV586M Dust Extractor (5 Pack)

Barcode:
5035048696743

DCV5861-XJ
M-Class Filters For DCV586M
Dust Extractor (Set of 2)



- M-Class Certified to meet EU legislation
- HEPA Certified
- Can be Used in Wet & Dry Applications

Barcode:
5035048696712

DCV586MT2-GB



- 2000W Brushless Motor provides powerful and market leading overload protection for increased performance
- Wireless vac activation by a remote key fob so there is no need to switch on at source for ease of use and saves time
- Audible Alarm alerts user of a drop in performance
- M-Class Compliant, < 0.1% dust escape through filter, suitable for use on construction sites
- TSTAK® Compatible configure to exact storage requirements for ease of use, enhanced mobility, saving time
- Automatic dual filter cleaning filter cleaned every 30 seconds, reduces filter clogging delivering constant air flow
- Recessed Battery Crevice provides maximum battery protection
- Wet and dry for maximum clean up flexibility and on vac 2.4m hose storage for ease of use
- Dust tight and water resistant for maximum protection against severe conditions, giving increased durability
- Heavy duty metal clips to quick and easy access to tank & filters
- 4mm reinforced polypropylene plastic provides high impact, drop resistant for increased durability
- Includes DCB118 fast battery charger, 2 x DCB546 6Ah/2Ah batteries, 2.4m x 32m extraction hose, 3mm AirLock adapter, stepped rubber AirLock adapter, remote fob and strap, fleece dust bag. Boxed in branded cardboard packaging



Barcode:
5035048691786



DWV9210-XJ

AIRLOCK DUST CONNECTION SYSTEM CONSTRUCTION KIT



- Twist lock action enables user to quickly move hose from tool to tool whilst retaining positive lock
- Swivels 360 degrees to prevent hose becoming twisted during use

Barcode:
5035048359631

DWV9000-XJ

AIRLOCK DUST CONNECTION SYSTEM MAIN CONNECTOR



- Screws directly to 35mm hose. Compatible with DEWALT and other extraction units
- Direct locking to compatible DEWALT tools
- Swivels 360 degree to prevent hose becoming twisted during use
- Twist lock action enables user to quickly move hose from tool to tool whilst retaining positive lock

Barcode:
5035048359679

DWV9120-XJ

AIRLOCK DUST CONNECTION SYSTEM STEPPED ADAPTER



- Swivels 360 degrees to prevent hose becoming twisted during use
- Stepped rubber adapter adds flexibility to system.
- Fits 35 and 38mm ID ports

Barcode:
5035048359716

DWV9220-XJ

AIRLOCK DUST CONNECTION SYSTEM WOODWORKING KIT



- Direct locking to compatible DEWALT tools
- Twist lock action enables user to quickly move hose from tool to tool whilst retaining positive lock
- Swivels 360 degrees to prevent hose becoming twisted during use

Barcode:
5035048359655

DWV9110-XJ

AIRLOCK DUST CONNECTION SYSTEM TAPERED RUBBER ADAPTER

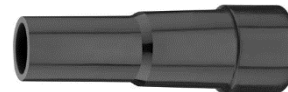

- Fits with the DWV9000 AirLock connector for quick and easy dust port connection
- Tapered rubber adapter fits tools with 29, 30 and 35mm ID ports
- Swivels 360 degrees to prevent hose becoming twisted during use

Barcode:
5035048363249

DWV9130-XJ

AIRLOCK DUST CONNECTION SYSTEM 35MM ADAPTER



- Swivels 360 degrees to prevent hose becoming twisted during use
- 35mm OD adapter fits tools with 35mm ID port

Barcode:
5035048359693

DWV9150-XJ

AIRLOCK DUST CONNECTION SYSTEM 35MM ANGLE ADAPTER



- Can be used as a handle in conjunction with floor cleaning kit
- Angle allows user to position hose away from tool
- 35mm Angle adapter fits tools with 35mm ID port
- Swivels 360 degrees to prevent hose becoming twisted during use

Barcode: 5035048359730



FLOOR CLEANING KIT FOR DUST EXTRACTORS

DCV9350-XJ

- Fits DWV901L and DWV902M dust extractors
- Metal Tubes for added durability
- Includes AirLock Adapter for direct connection to vacuums

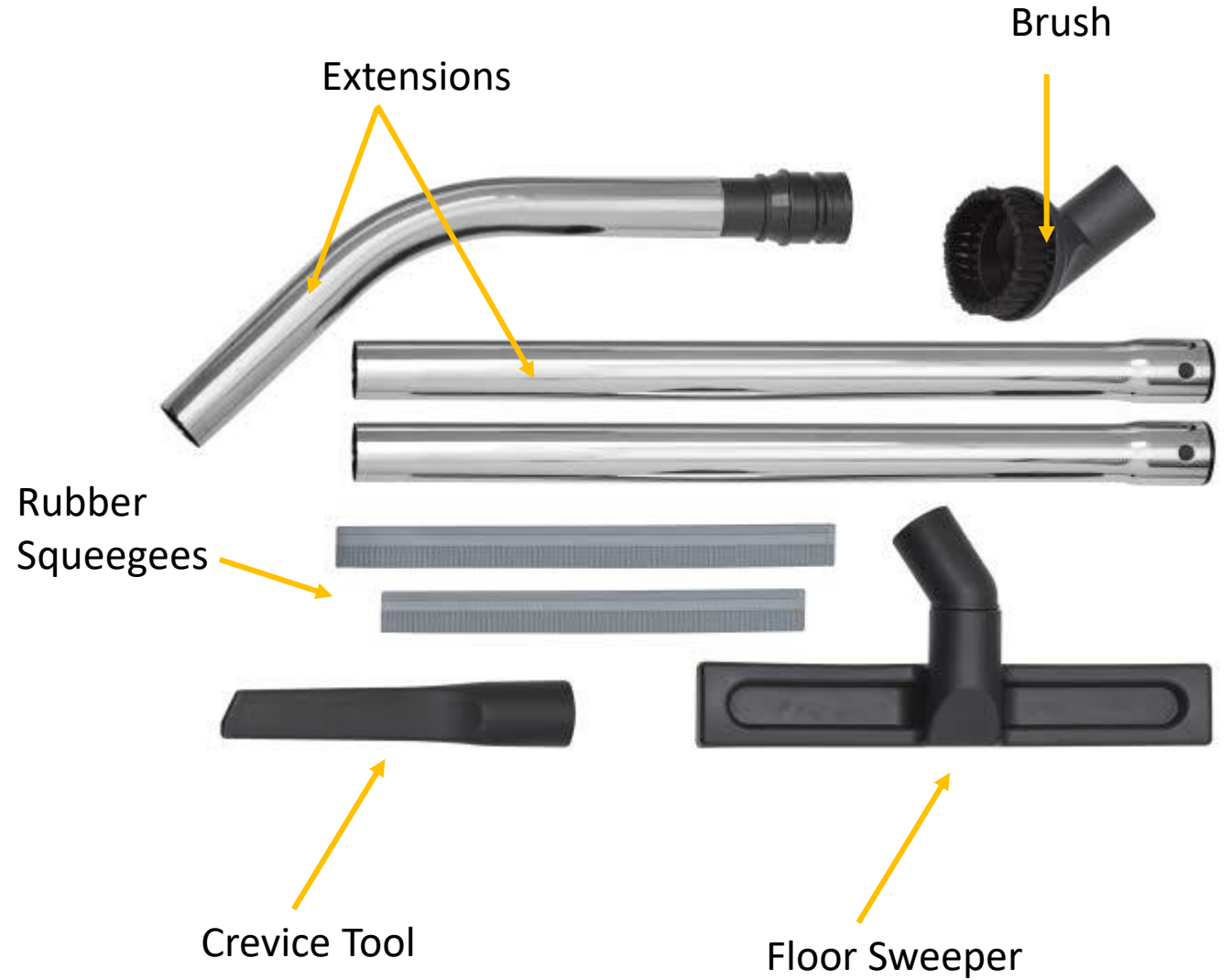

DEWALT 1 Year
Guarantee

Barcode:
5035048651988

StanleyBlack&Decker Login | Sign Up | Language (en-US)

TRAINING

Home Course Catalogue Contact

Welcome to the Stanley Black and Decker e-Learning Centre!

Whether it's residential construction, commercial construction, repair or renovation, we've got you covered. We've been here for you since 1843. And since we know you count on us to deliver the best, we push ourselves every day to deliver the toughest, strongest, most innovative power tools, hand tools and fasteners on the market. It is our goal not only to provide you with the best products, but also to provide you with the training and support you may need in order to understand the features, benefits and the range of applications our products can be used for.

All the courses are delivered through our high quality Learning Management System, allowing you to study online at your own pace, from anywhere with an internet connection.

[REGISTER](#) [LOGIN](#) [SELECT LANGUAGE](#) 



<https://go.bluevolt.com/SBD/Home>

Available Now !



To the best of our knowledge, all descriptions, illustrations, specifications in this presentation are correct at the time of publishing. We cannot however be held liable for any inaccuracies of description, illustrations, specifications and reserve the right to change without notification. DEWALT® is a registered trademark of Stanley Black & Decker